

Design of High Voltage Pulse Generator and Receiver Circuit for Ultrasonic velocity and Absorption Measurements In liquids

Dr.Shaik Abdul Jaffar¹, Prof. K. Malakondaiah², Prof. Y.B. Gandole³

Research Scholar, Department of Instrumentation, Sri Krishna deveraya university, Anantapuramu, India¹

Professor, Department of Instrumentation, Sri Krishna deveraya university, Anantapuramu, India²

Prof., Dept. of Electronics, Adarsha Science J.B.Arts & Birla Commerce, Mahavidyalaya, Dhamangoan, Rly, India³

Abstract: This paper discusses the design and development of a single channel transceiver for broad bandwidth ultrasound applications.. The transceiver has the pulser as transmitter and a broad bandwidth receiver. A high frequency ultrasound transducer is used both for the transmission of ultrasound pulse and for receiving the ultrasound echoes. The pulser circuit is a high voltage, high speed, switching circuit designed for 20 V pulse amplitude and pulse width as low as 10 ns. The preamp is a low noise, wide bandwidth amplifier and the time gain compensation circuit has a low noise figure and a bandwidth of 15 MHz. Custom, miniaturized PCB's have been fabricated and tested for the R.F. electronics. The performance characteristics of 5 MHz transducers are tested and calibrated.

Keywords: Pulse generator, Pulser-Receiver, Ultrasonic measurements.

I. INTRODUCTION

Ultrasonic pulser-receivers are well suited to general purpose ultrasonic testing. Along with appropriate transducers and an oscilloscope, they can be used for flaw detection and thickness gauging in a wide variety of metals, plastics, ceramics, and composites. Ultrasonic pulser-receivers provide a unique, low-cost ultrasonic measurement capability. The pulser section of the instrument generates short, large amplitude electric pulses of controlled energy, which are converted into short ultrasonic pulses when applied to an ultrasonic transducer. Most pulser sections have very low impedance outputs to better drive transducers. Control functions associated with the pulser circuit include:

- ❖ Pulse length or damping (The amount of time the pulse is applied to the transducer.)
- ❖ Pulse energy (The voltage applied to the transducer. Typical pulser circuits will apply from 100 volts to 800 volts to a transducer.)

In the receiver section the voltage signals produced by the transducer, which represent the received ultrasonic pulses, are amplified. The amplified radio frequency (RF) signal is available as an output for display or capture for signal processing. Control functions associated with the receiver circuit include

- ❖ Signal rectification (The RF signal can be viewed as positive half wave, negative half wave or full wave.)
- ❖ Filtering to shape and smooth return signals
- ❖ Gain, or signal amplification
- ❖ Reject control

The pulser-receiver is also used in material characterization work involving sound velocity or attenuation measurements, which can be correlated to material properties such as elastic modulus. In conjunction with a stepless gate and a spectrum analyzer,

pulser-receivers are also used to study frequency dependent material properties or to characterize the performance of ultrasonic transducers. This work presents circuits that are developed to excite ultrasonic transducers transmitters and to receive the coming signals of ultrasonic transducers receivers [1-3]

II. DESIGN CONSIDERATION

(i) High frequency pulse generator:

The First part to be designed was the transmitter (Fig.1). It was decided to use an analog circuit to generate the driver frequency, mostly due to better accuracy and reliability. An LM555 timer constantly provides an square signal of the 5MHz frequency; this signal is connected to the monostable multivibrator which generates pulse width 3 us. The sample rate is 500 Hz.

The output of 74121 is applied to the IRF530 Power MOSFET which utilize advanced processing techniques to achieve extremely low on-resistance per silicon area. This benefit of the IRF530, combined with the fast switching speed and ruggedized device design that HEXFET power MOSFETs are well known for, provides the designer with an extremely efficient and reliable device for use in a wide variety of applications. The amplitude of output pulse uses 60 V peak to peak; which is given to sender transducer (Tx).

In the design of a practical pulse generator, parasitic capacitors associated with the MOSFETs and the coaxial cable connecting to the transducer have to be considered. These capacitors keep the pulse generator output at high voltage for a long period that could saturate the high-gain echo amplifier and also increase the leakage current that may create safety issues. Thus, at the end of each pulse train, discharging the parasitic capacitors to zero potential is essential.

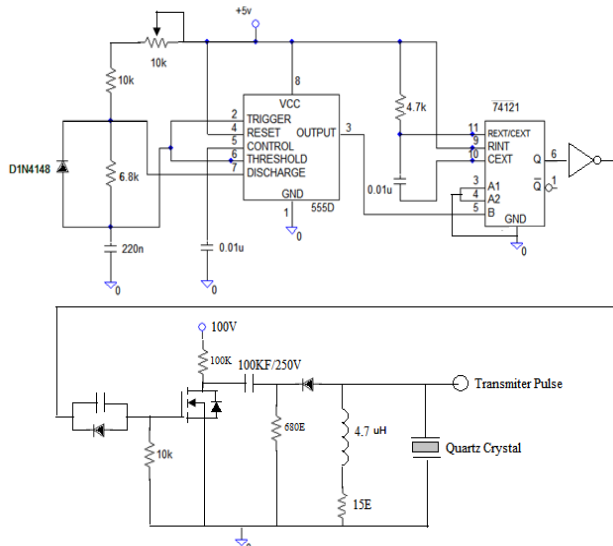

Fig. 1: High frequency pulse generator

(ii) Wide band Receiver

In practical situations, the received echo signal intensity can be less than 1% of that sending out from the transducer. A high gain amplifier is required to amplify the echo signal received from the transducer. The circuit diagram of wideband receiver is shown in figure 2.

An amplifier consists of single stage, which is assembled by using the AD822 which is a dual precision, low power FET input op amp that can operate from a single supply of 5 V to 30 V or dual supplies of ± 2.5 V to ± 15 V. It has true single-supply capability with an input voltage range extending below the negative rail, allowing the AD822 to accommodate input signals below ground in the single-supply mode.

Output voltage swing extends to within 10 mV of each rail, providing the maximum output dynamic range. Offset voltage of 800 μ V maximum, offset voltage drift of 2 μ V/ $^{\circ}$ C, input bias currents below 25 pA, and low input voltage noise provide dc precision with source impedances up to a gigaohm. The 1.8 MHz unity-gain bandwidth, -93 dB THD at 10 kHz, and 3 V/ μ s slew rate are provided with a low supply current of 800 μ A per amplifier. The output signal is then fed to LH0002 which is a general purpose buffer. Its features make it ideal to integrate with operational amplifiers inside a closed loop configuration to increase current output. The symmetrical output portion of the circuit also provides a low output impedance for both the positive and negative slopes of output pulses.

The AD602 dual-channel, low noise, variable gain amplifiers are optimized for use in ultrasound imaging systems but are applicable to any application requiring precise gain, low noise and distortion, and wide bandwidth. Each independent channel provides a gain of 0 dB to +40 dB in the AD600 and -10 dB to +30 dB in the AD602. The lower gain of the AD602 results in an improved signal-to-noise ratio (SNR) at the output. However, both products have the same 1.4 nV/ $\sqrt{\text{Hz}}$ input noise spectral density. The decibel gain is directly proportional to the control voltage, accurately calibrated, and supply and temperature stable.

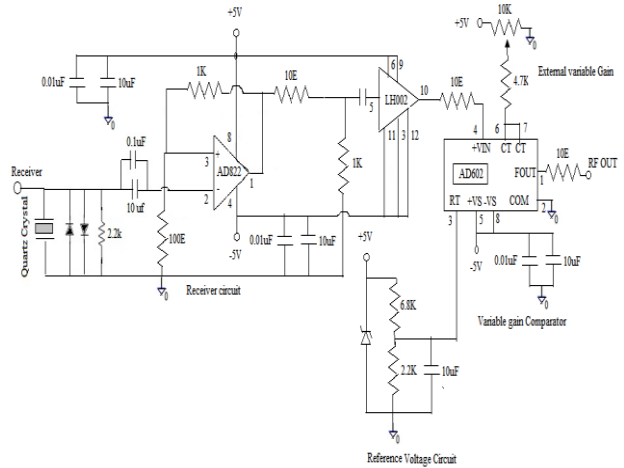

Fig.2 Wide band receiver

III.MEASURING TECHNIQUE

For the measurement of ultrasonic velocity and attenuation, the Sender Transducer(Tx) is firmly fixed at one end of the measuring cell, while Receiving Transducer(Rx) if fixed to movable scale having least count of 0.005cm.

The liquid sample was contained in a glass tube as shown in figure 3.

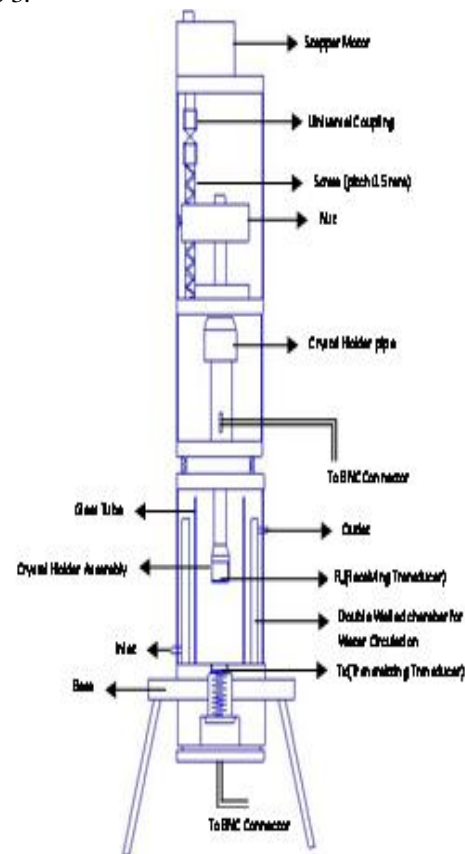

Fig: Measuring cell

A glass tube of height 160mm and outer diameter is 60.5mm and inner diameter is 53.5mm. The glass tube was inserted in an inner space of Double walled chamber which was made of brass tubes. Dimensions of double walled chamber are: height of double walled chamber is 145mm, outer diameter 82.7mm and inner diameter is

61.5mm. The Double walled chamber was provided with inlet and outlet for constant temperature water circulation. Water circulation arrangement was made through thermostat. The lower surface of the glass tube and double walled chamber were in the same plane. The lower portion of Glass tube is partially closed leaving an opening of 24mm diameter in which a gold plated X-cut Quartz crystal of natural frequency 5MHz and of approximately 20mm diameter is held firmly with a Silicon O-ring. The Crystal is kept pressed by a Silicon O-ring held in position by three screws and tightened with optimum pressure. The Crystal is in direct contact with the medium under investigation.

The Receiving Transducer Rx is kept in Crystal holder assembly and the Crystal is kept pressed by a Silicon O-ring and tightened with optimum pressure by using chuck nut. The Receiving Transducer Rx is coupled to micrometer via Crystal holder pipe and Dottle–Neck arrangement. The micrometer screw is having a pitch of 0.05mm and it is connected to Stepper motor via Universal Coupling. Knowing the distance and transit time, Ultrasonic velocity and absorption measurements can be computed. The transmitting and received pulse is displayed on personal computer using ADC card.

IV. RESULT AND DISCUSSION

The system is checked by measuring the ultrasonic velocity and absorption in some organic and n-alcohols liquids at 5 MHz frequencies and at 30°C temperature

Table 1 shows the comparison between the literature values and measured values of ultrasonic velocity for the liquid samples.

Table 2 shows the comparison between the literature values and measured values of ultrasonic absorption for the liquid samples.

Table1. Ultrasonic velocity measurements at 30°C for 5MHz Frequency

S. No	Sample	Ultrasonic velocity (m sec ⁻¹)		Reference
		Present study	Literature value	
1	Benzene	1286.52	1286.00	Takagi et al ⁴
2	n-Hexane	1052.32	1052.00	N. Santhi et al ⁵
3	Methanol	1087.46	1087.00	Plantier et al ⁶
4	n-Propanol	1192.19	1192.80	N.Santhi et al ⁵
5	n-Butanol	1225.51	1225.00	Plantier et al ⁶

Table2: Ultrasonic absorption measurements at 30°C for 5MHz Frequency

S. No	Sample	Ultrasonic absorption coefficient $\alpha/f^2(10^{-15} \text{ Np m}^{-1}\text{Hz}^2)$		Reference
		Present study	Literature value	
1	Benzene	909.89	909.81	Agnihotri p. k. et al ⁷
2	n-Hexane	54.50	53.50	Stephen hawley et al ⁸
3	Methanol	31.90	31.70	Stephen hawley et al ⁸
4	n-propanol	62.50	62.70	Stephen hawley et al ⁸
5	n-Butanol	77.27	77.40	Stephen hawley et al ⁸

V. CONCLUSION

The stability, accuracy and sensitivity of the system can be seen from the table1 and table2, It is observed that the experimental values of ultrasonic velocity and absorption at 5MHz are found to be in good agreement with literature values. All the measured values are within 0.02% accuracy. Thus the proposed design shows good performance.

REFERENCES

- [1] Auld, B.A., Acoustic Fields and Waves in Solids, Vol I & II, 2nd edition Krieger Publishing Company, February 1990; ISBN: 089874783X
- [2] Cartz, Louis, Nondestructive Testing : Radiography, Ultrasonics, Liquid Penetrant, Magnetic Particle, Eddy Current, ASM Intl; ISBN: 0871705176
- [3] Krautkramer, Josef and Krautkramer, Herbert, Ultrasonic Testing of Materials, 4th/revised edition, Springer Verlag, November 1990, ISBN: 0387512314
- [4] Takagi T., Sawada K., Urakawa H., J. Chem. Thermodynamics., vol. 36, pp.659, 2004.
- [5] N.Santhi, P.L. Sabarathinam, J. Madhumitha, G. Alamelumangai, M.Emayavaramban, Intl. letters of Chem. Phys. and Astro., vol.2 , pp.18, 2013.
- [6] F.Plantier et al. , J. phys. D: appl. Phys. vol.35, pp.1063, 2002.
- [7] Agnihotri P. K., Adgaonkar C. S., Theoretical evaluation of ultrasonic velocity in binary liquid mixtures, Research and Industry, vol.33,pp.139, 1988.
- [8] S. Hawley, J. Allegra and G. Holton., J. Acoust. Soc. Amer., vol.47, pp.137- 143, 1970.